

VD-A Desk

<Flat Desk> <Option>

Instruction/Assembly Manual



Contents			
Safety Instructions	2	Assembly Instructions	6~9
Installation	3	Operation Guide	10~11
Materials and Surface Finish	3	【Option】 Wiring Tray	12
Instructions to Extend the Life of Product	3	【Option】 Wiring Vertical Duct	13
Parts Name	4	【Option】 Central Drawer	14
Parts List	5	【Option】 Luggage Hook	15

Safety Instructions (Make sure to follow these instructions)

⚠ Caution

Do not handle roughly, or use improperly. Failure to follow the safety precautions may cause injury or damage to the product.

- Do not step/stand on the desk or wagon. Failure may cause you to fall and get injured.
- Do not place any dangerous objects (a fragile article, chemical, living thing, etc.) in the desk drawer.
- Do not use as a carrier.

Do not put your fingers or hands into the spaces or moving parts of the product. This may lead to injuries.

- When housing a wagon under the Worktop of the desk, be careful not to get hands or fingers caught between the wagon and the Worktop. Do not forcibly put your fingers in the wiring hole on the Worktop. The fingers may be stuck to be injured.

* If the wiring cap on the tabletop falls into the wiring hole, be sure to get under the tabletop to take the cap out of the hole.



Be careful of the following items since it may cause injury or damage the product.

- Do not hang on or lean on to the product. Failure may cause serious damage to the product.
- Do not place any heavy objects on the corner of the desk.
- If found unstable due to loosening of bolts or screws, retighten them.



Assign two or more persons to the adjuster operation. Securely hold the product not to cause hands or feet to be caught.

Do not load anything more than the maximum loading capacity of the product. It may cause you to fall or damage to the product.

Worktop (Uniformly distributed weight) 150kg (330lb)

Luggage hook (Uniformly distributed weight) 5kg (11lb)

* What is "Uniformly distributed weight" ?

It means to load on a work surface, etc. evenly. Uneven loading on the product may cause balance loss and thus drop or fall.

Do not reconfigure. This leads to malfunction or accident.

- Reconfiguring by yourself causes the product to malfunction or accident. Okamura will have no responsibility for any disadvantages caused by remodeling.

Do not disassemble or repair on your own.

- Do not attempt to disassemble or repair the product yourself. Please contact our official dealers when needed.

Do not move the desk with equipment connected. Failure may cause equipment to be disconnected or overturned.

When moving the desk for layout change or the like, be sure to follow the instructions below.

- Remove all items on the desk and in the drawer.
- Two or more persons shall be assigned to hold safe areas in the lower portion of the desk and move the desk.

Installation

Indoor use only.

- No outdoor or waterfront use.
- When placing alongside windows, use curtains or blinds to avoid direct sunlight. Do not place product under heater or air-conditioner exhausting high temperature air.
- Make sure to place the product on an even floor when using. Failure may cause the product to deform or to be damaged.
- Adjust using the adjusters so the product is horizontal to the floor.

Materials and Surface Finish

Part		Materials	Surface Finish	
Flat Desk	Worktop	Surface materials	High pressure laminate	
		Core material	Steel	
		Coaming	ABS resin	
		Wiring cap	ABS resin	
	Back Panel	Steel	Amino alkyd resin coating	
Leg	Body	Steel	Amino alkyd resin coating	
	Adjuster		-	
Option	Wiring Tray		Steel	
	Wiring Vertical Duct		Steel	
	Central drawer	Front panel	Steel	Amino alkyd resin coating
		Body	Steel	Amino alkyd resin coating
		Rail Frames	Steel	Amino alkyd resin coating
	Luggage hook		Steel	Amino alkyd resin coating

* Please understand that product specifications might change without prior notification due to improvements made to the product.

Instructions to Extend the Life of Product

Please follow instructions below. Failure may cause serious damage to the product and Okamura will have no responsibility for any damages.

Operating Precautions and Maintenance

- If the product has become unsteady due to loosening of the bolts or screws during use, retighten them immediately.
- Do not use any sharp - edged objects such as a knife on the Worktop. Failure may damage the Worktop.
- Do not place any hot objects directly on the Worktop. Failure may leave white stains.
- Avoid direct exposure to steam. Failure will cause rust.
- Wipe off any water on the Worktop with a dry and soft cloth.
- Immediately wipe off tea, coffee, detergent, chemical, etc. if any spilled.
- This instruction manual is very important, so store it in an easily accessible location.
- Regular maintenance is recommended for long-life use. Make your request to us early for inspections and repairs (fees required) when the warranty period has expired.

Maintenance

【For daily care】

- Wipe off with a soft cloth dampened with water.
- When it gets dirty, moisten the cloth with thin neutral detergent. Use a damp cloth to wipe off detergent completely. Wipe dry with a dry cloth.

〈Caution〉

- Avoid causing a circular stain, remove not only the stain but also wipe off thoroughly around the stain.

Parts Name

The figure shows the assembled flat desk.

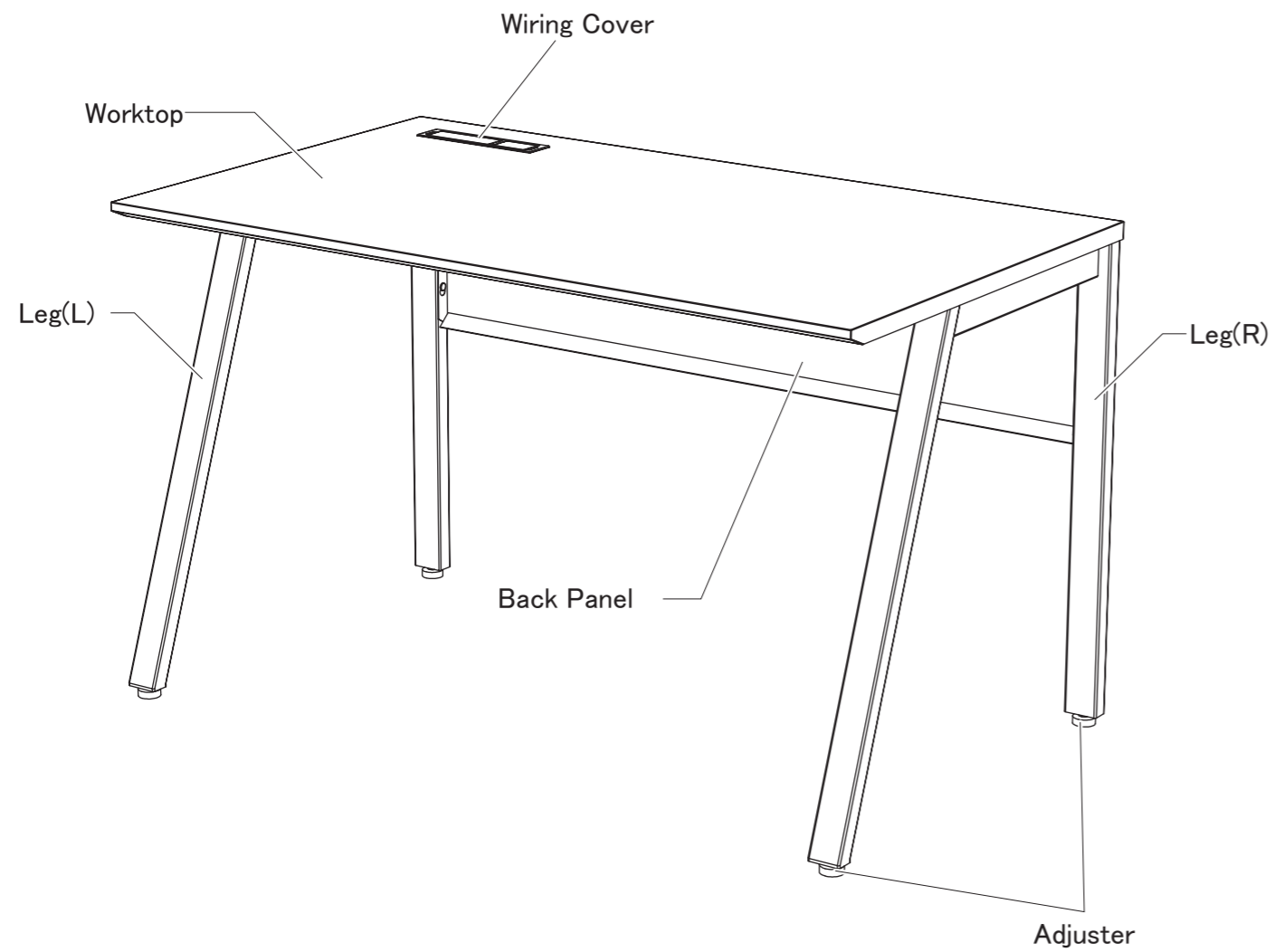

Parts List

Before starting the assembly, make sure that all the following parts are available.

Assembly tool



Phillips-head screw driver

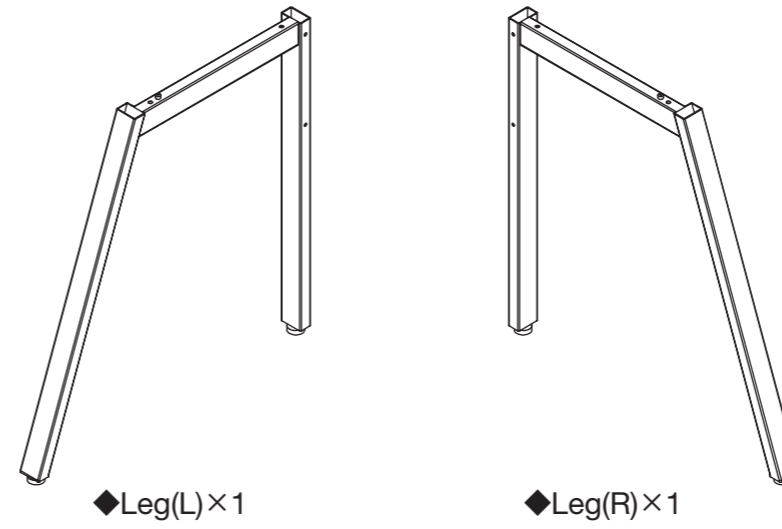

Screw **A**  × 4
(M6-12L)

Screw **B**  × 4
(M6-60L)

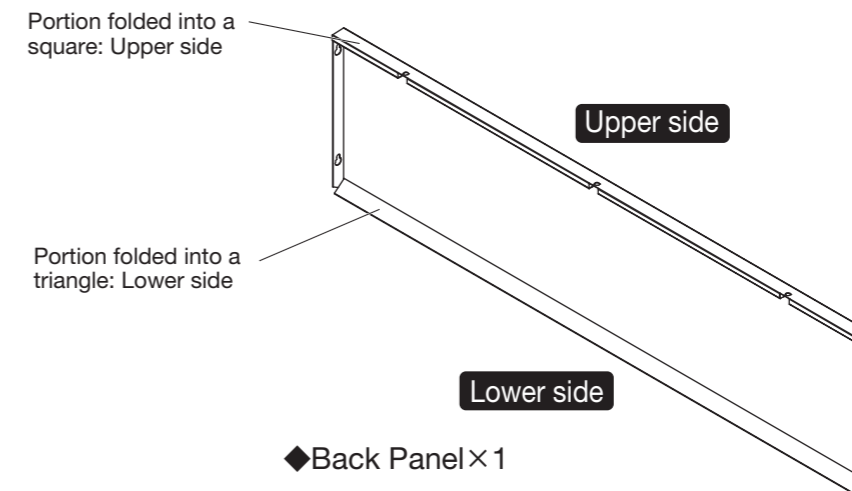
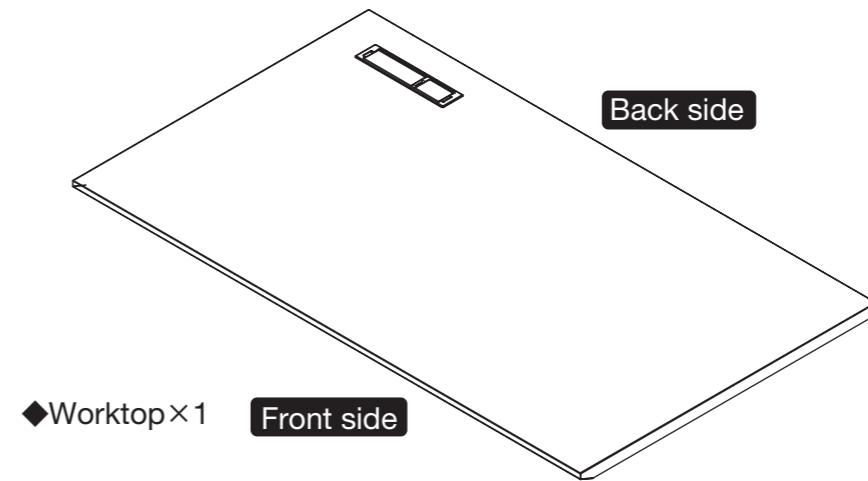

Assembly Instructions

⚠ Notes on Assembly

Carefully read the following assembly manual, and conduct the assembly by two persons in a flat place. Make sure to use all the supplied parts and securely tighten the screws to correctly assemble the product. Avoid incomplete assembly which is dangerous and will cause a falling accident or physical damage.

1 Attaching the Back Panel to the Leg

1

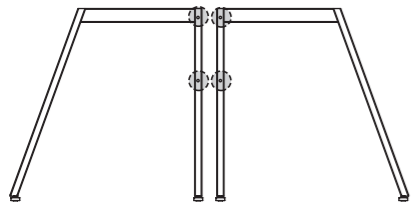

Screw A  × 4

Tighten Screw A half way to the screw hole in the inner side of the Leg (two each on right and left sides) using the screwdriver

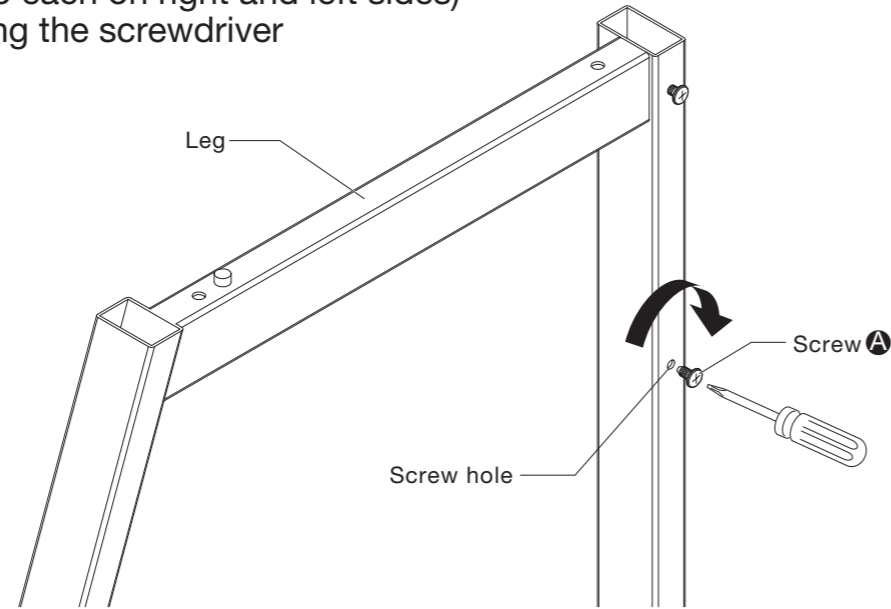

2



Before attaching the Back Panel, check its vertical orientation (top and bottom).

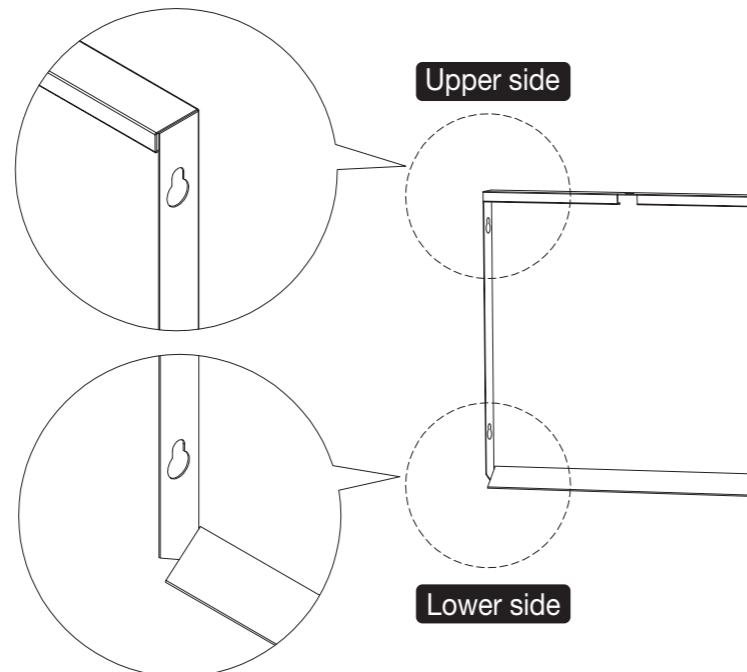

3

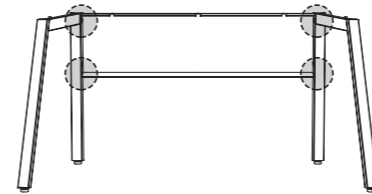

Hook the Back Panel on each Screw A (two each on right and left sides).

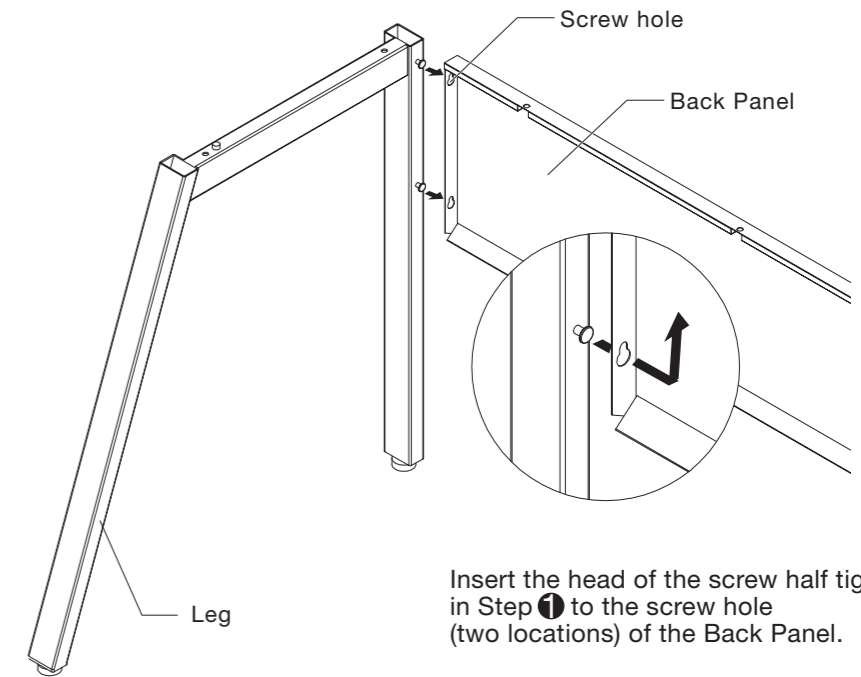

Insert the head of the screw half tightened in Step 1 to the screw hole (two locations) of the Back Panel.

4

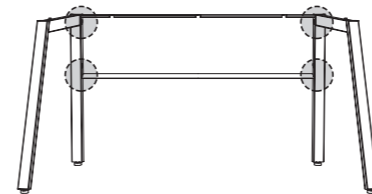

Tighten Screw A (two each on right and left sides) to temporarily fix the Back Panel to the Leg.

Point!

To temporarily fix the Back Panel is to keep the screws loosened without being fully tightened. This will prevent the product from being assembled with misalignment and facilitate smooth tightening of the screws.

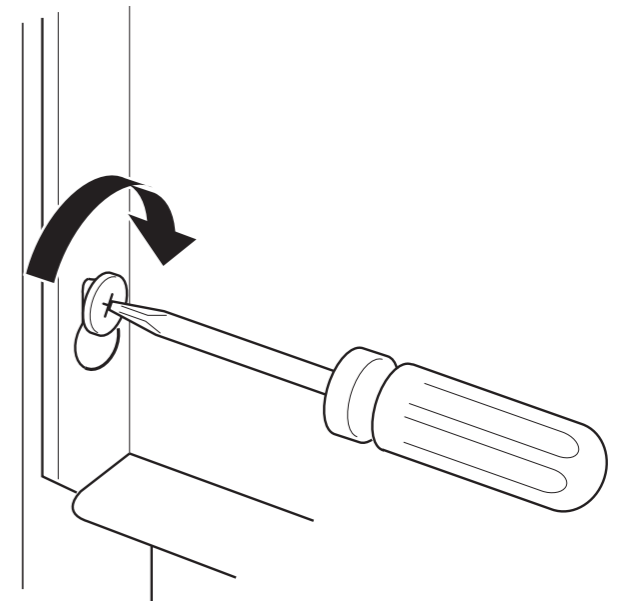

2 Attaching the Worktop

Caution Be sure to move the Worktop by two or more persons when it is necessary.

1

If both right and left Legs are fixed to the back panel, the product will be as shown in the figure.

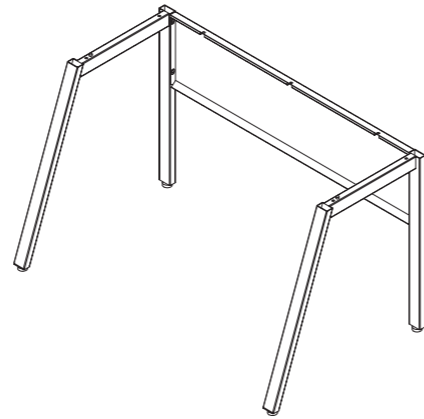

2

Bottom side of Worktop

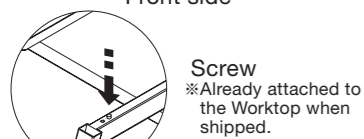
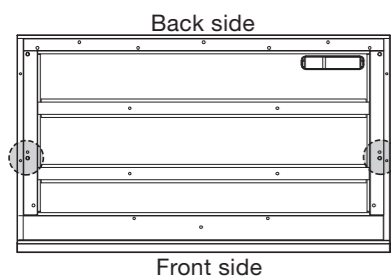

Screw
※Already attached to the Worktop when shipped.

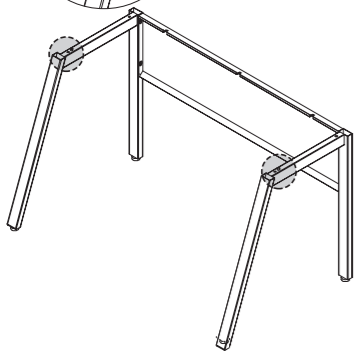

Confirm the front side and back side of the Worktop, and align the screws in the bottom side of the Worktop with the screw holes of the leg (two locations).

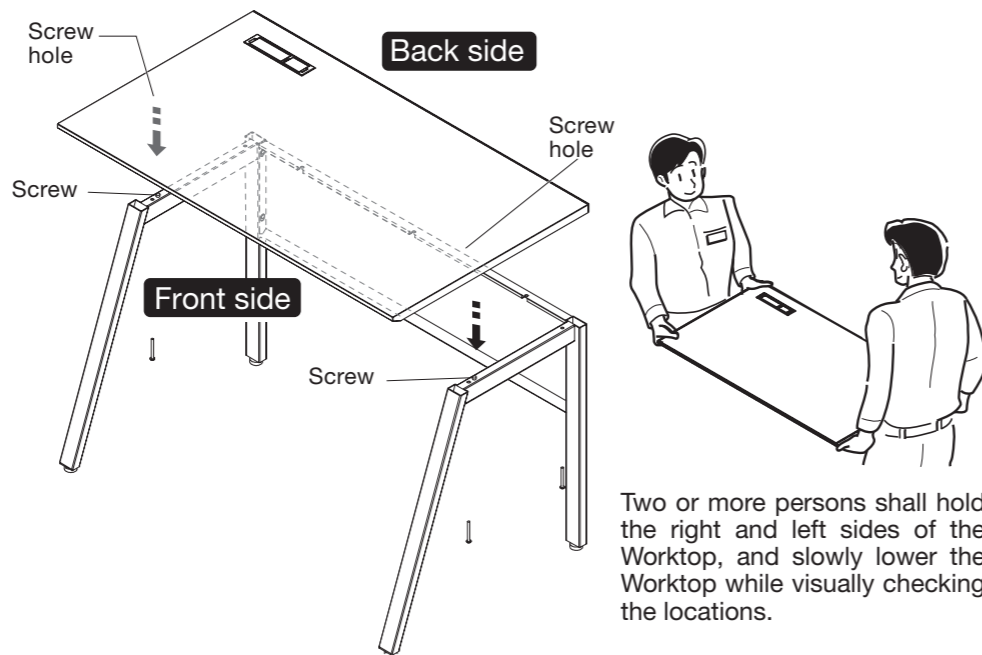

Two or more persons shall hold the right and left sides of the Worktop, and slowly lower the Worktop while visually checking the locations.

Place the Worktop while inserting the screw heads to the screw holes (one each on right and left sides).

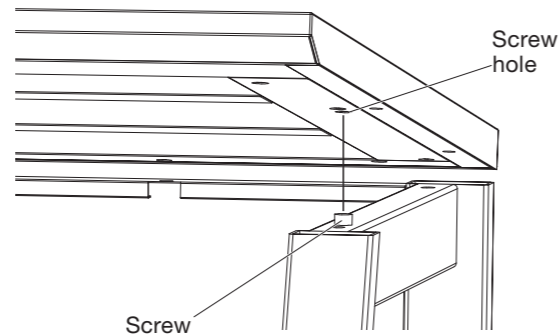

Caution

Be careful not to have your fingers, clothes, etc. caught between the Worktop and the leg.

3

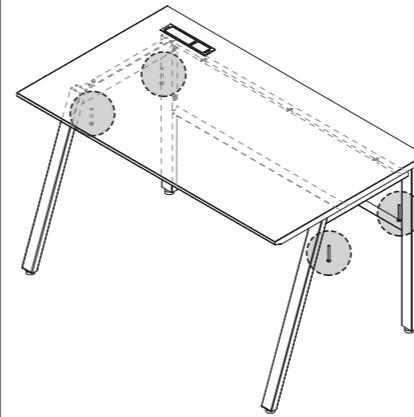

Screw **B** × 4

Tighten Screw **B** from the upper bottom side of the Leg to fix the Worktop to the leg (four locations).

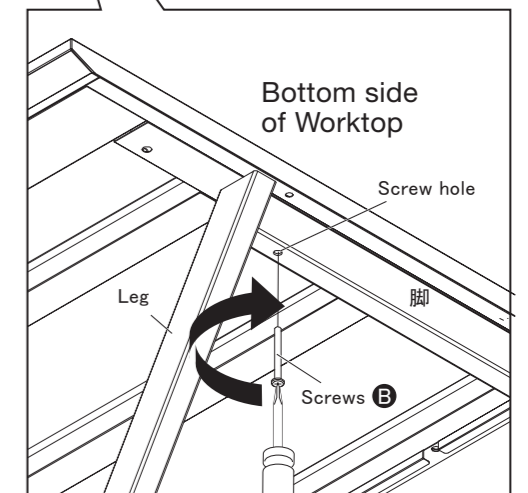
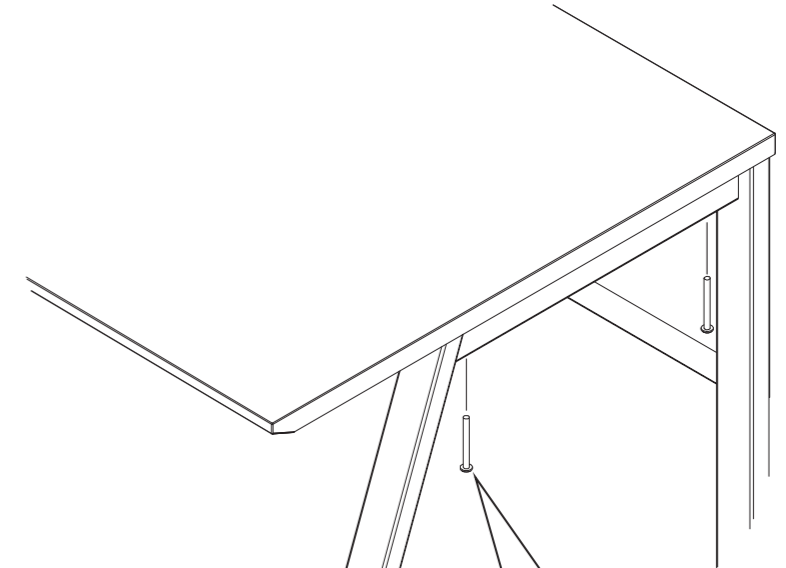

Supplementary

If a screw hole is misaligned, check whether the screw heads are securely fit to the holes in Step 3.

Fully tighten all the screws of the Back Panel and Worktop.

Now the assembly is completed. Then, operate the adjuster.

Adjusting The Worktop height

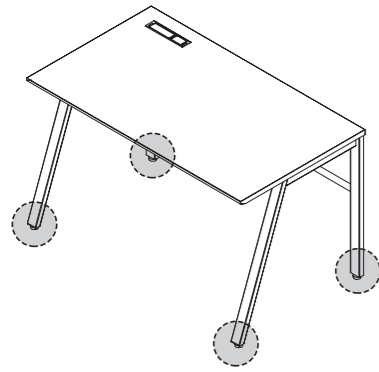

The Worktop height can be adjusted by turning the adjuster under the Legs in the range of 0 to 20 mm. When placing the product, be sure to level the Worktop by the adjuster.

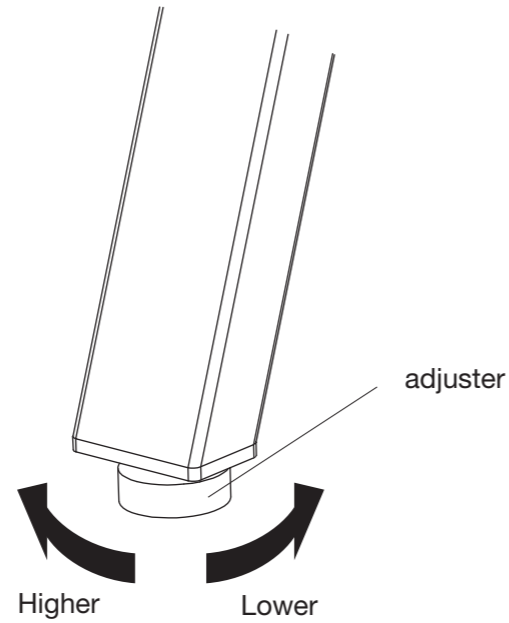

To keep the desk and the floor level, adjust it with the adjuster.

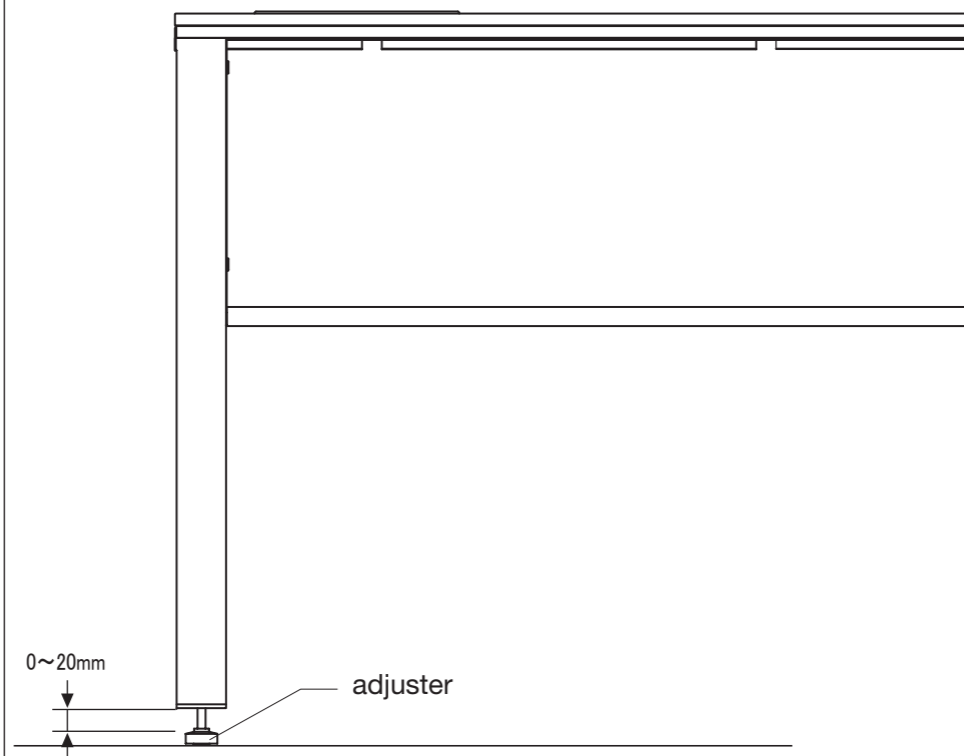

Caution

Be sure to perform height adjustment with more than two people using extreme caution so as to prevent your hands and fingers from getting caught.

Neatly arranging the wiring

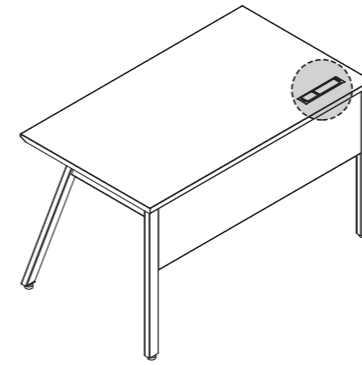

◆ Wiring cover

The Worktop is equipped with a wiring cap with covers.

Using the wiring hole

① Open the hatch of the wiring cover, and insert the cable plug in the hole.

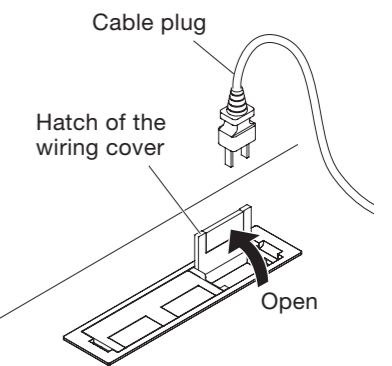

② Fold the flap at the center of the hatch.

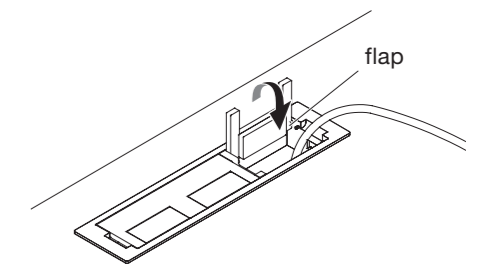

③ Close the hatch.

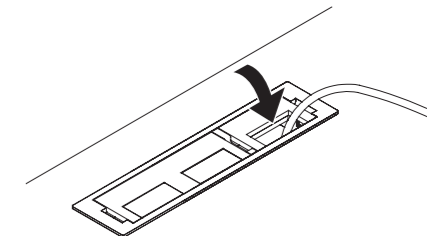

【Option】 Wiring Tray

Parts List

Before starting the assembly, make sure that all the following parts are available.

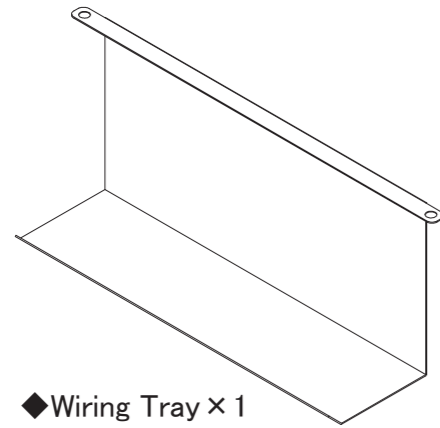

Assembly tool

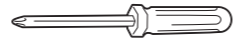

Phillips-head screw driver

Screw **A**  × 2
(M6-12L)

Assembly Instructions

Align the wiring tray with the installation holes behind the wiring cap portion on the back side of the worktop, and securely fix it using two screws **A**.

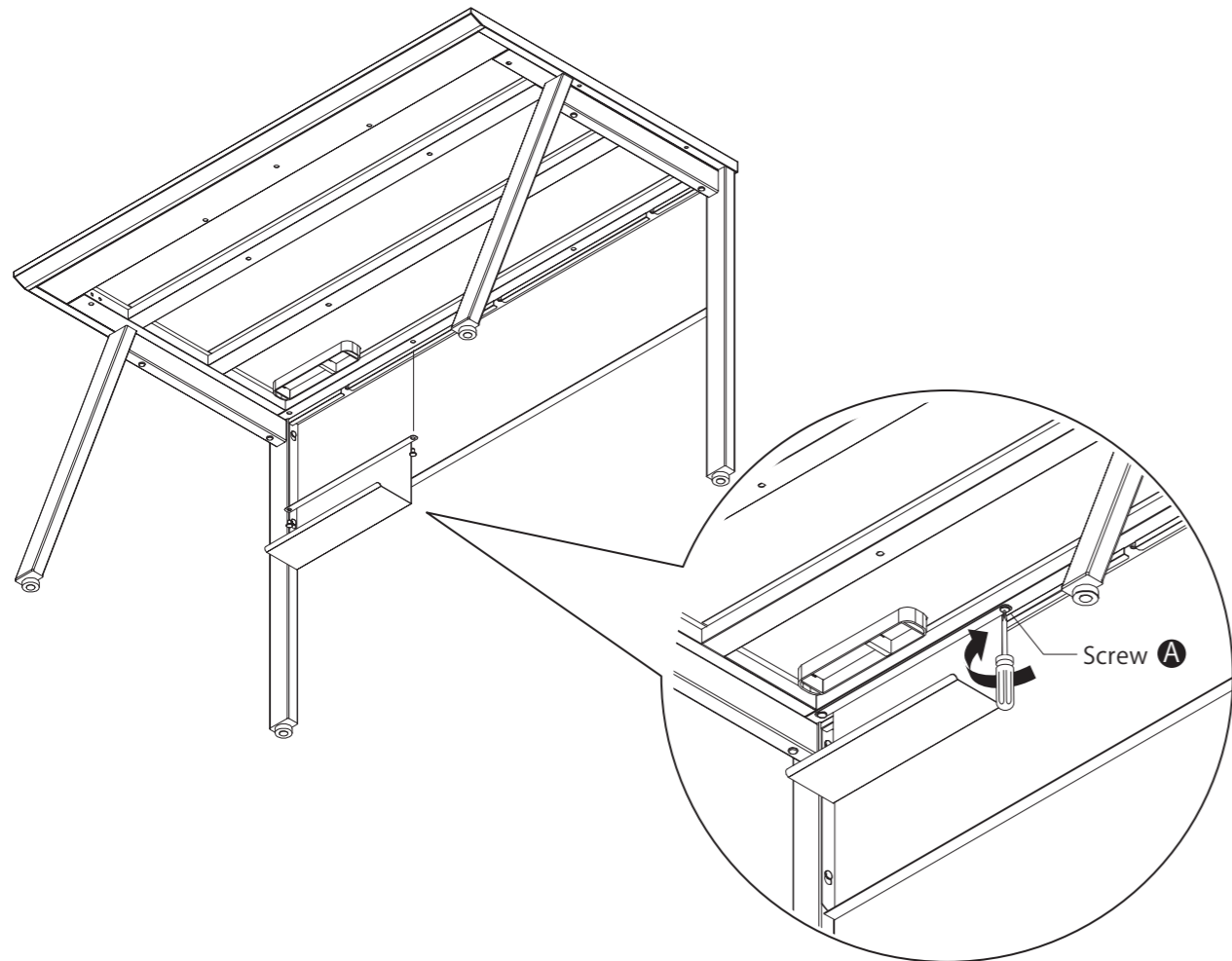

【Option】 Wiring Vertical Duct

Parts List

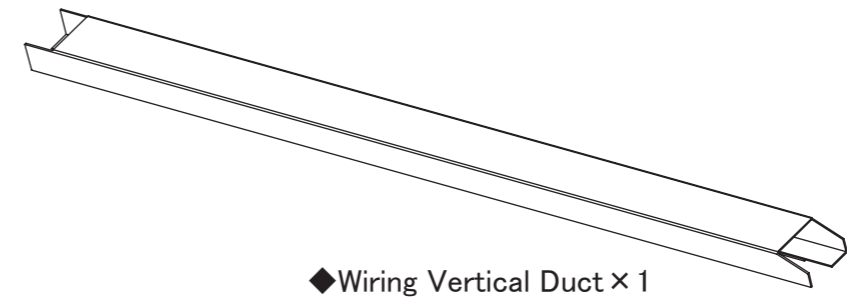

Assembly and Usage Instructions

1 Arrange the wiring

Arrange the cables and cords according to the position and direction.

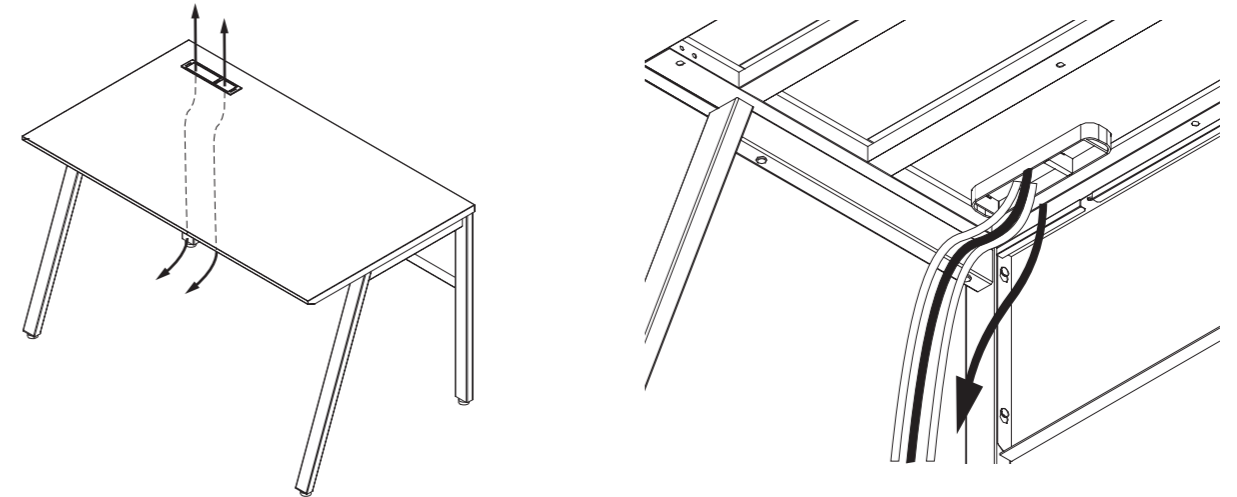

2 Install the wiring vertical duct

Place the cables and cords into the wiring vertical duct, and attach the duct to any position on the inner side of the leg.

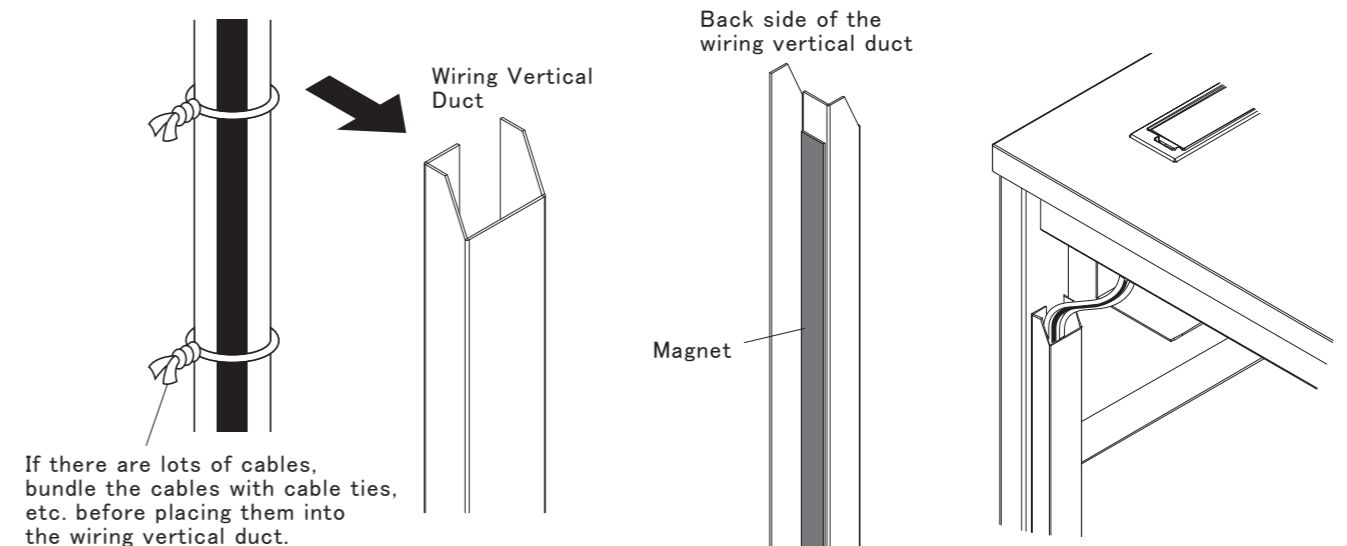

【Option】 Central Drawer

Parts List

Before starting the assembly, make sure that all the following parts are available.

Assembly tool

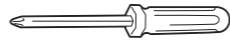

Phillips-head screw driver

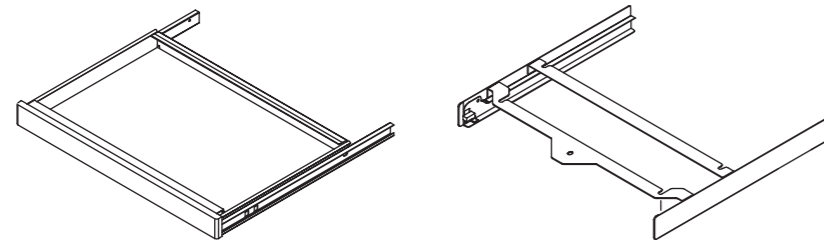

◆Drawer body × 1

◆Rail × 1

Screw **A**  × 5
(M6-12L)

Assembly Instructions

1 Install the rail

Remove the drawer body from the rail, firmly fix the rail to the nuts on the back side of the worktop using five screws **A**.

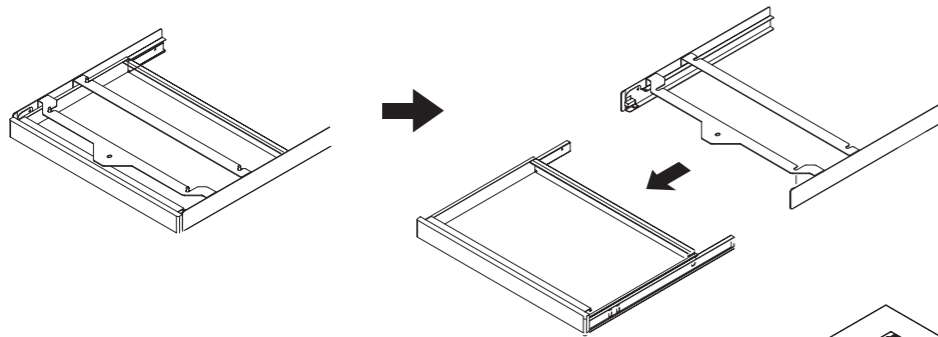

2 Attach the drawer body

Attach the drawer body to the installed rail.

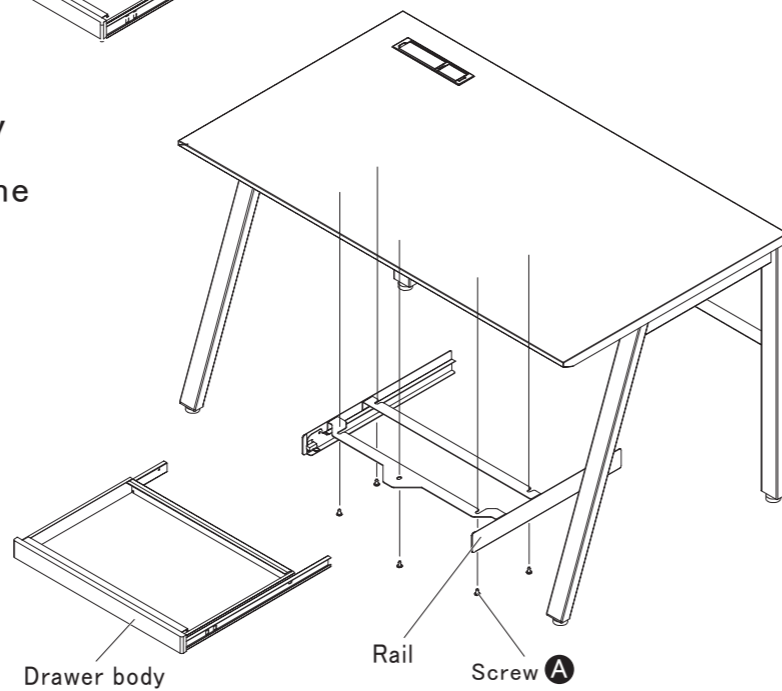

【Option】 Luggage Hook

Parts List

Before starting the assembly, make sure that all the following parts are available.

Assembly tool



Phillips-head screw driver

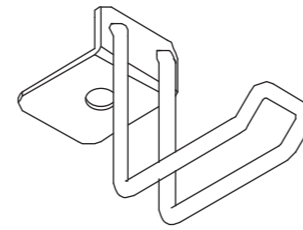

◆Luggage hook × 1

Screw **A**  × 1
(M6-12L)

Assembly and Usage Instructions

Insert the hook into the space inside the frame at the back side of the worktop, securely fix it by tightening the screw **A** from below.

* The hook can be installed on either the left or right side.

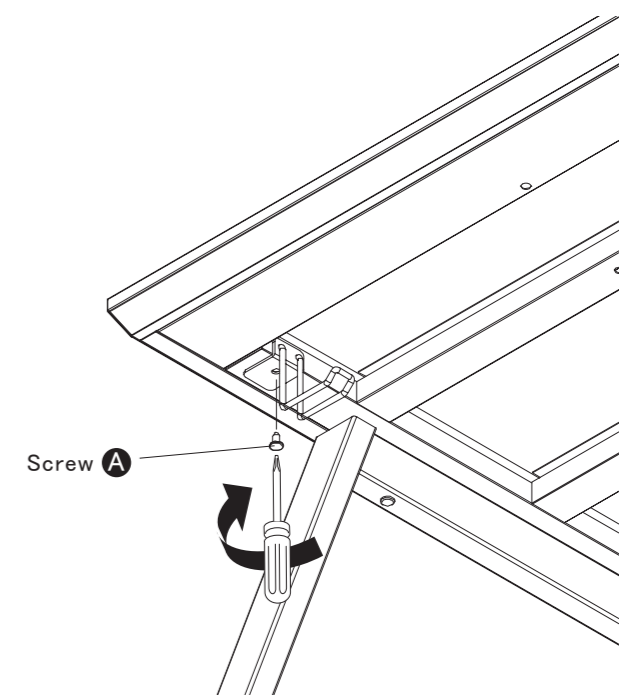
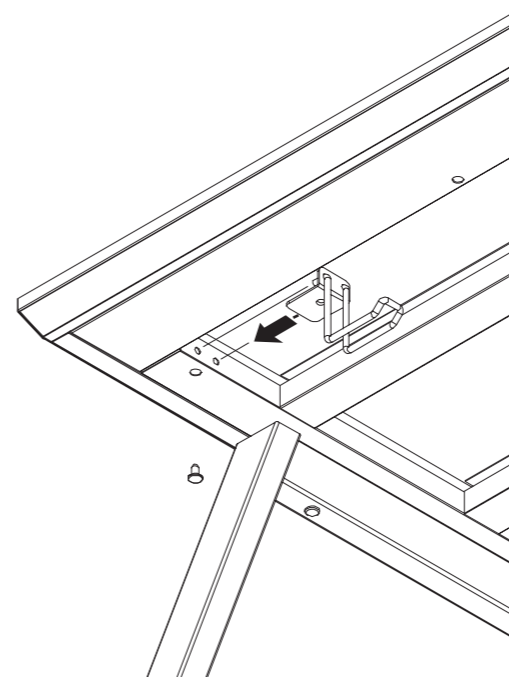

⚠ Caution

Do not exceed the maximum load capacity (5 kg) of the luggage hook.