

Components Plant box

Make sure that you have all of the necessary parts before assembling.

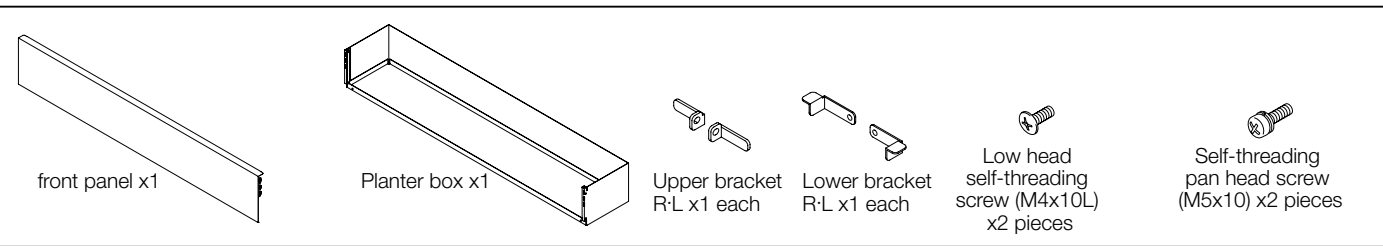

Assembly Instructions Plant box

Follow the instructions to ensure proper assembly.

1 Mounting of the planter box

- ① Place the main unit of the box on the shelf.
- ② Insert the mounting bracket into the slit of the shelves main unit and attach to box with round machine screw with spring washer (M4x10L). (1 for each location)
- ③ Insert the fall stopper bracket into the planter box and use the truss self-threading screw (M4x10L) to attach. (1 for each location)

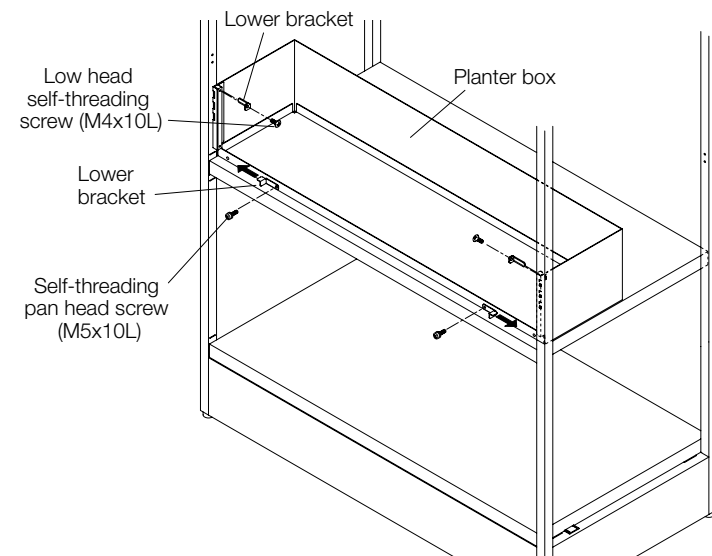

2 Mounting of the planter box's front panel

- ① Place the plants inside.
- ② Hang the top part of the front panel on the the main unit front panel and hang the left and right hooks.
- ③ Once the hooks are hung on the front panel, confirm that they are mounted hanging down.

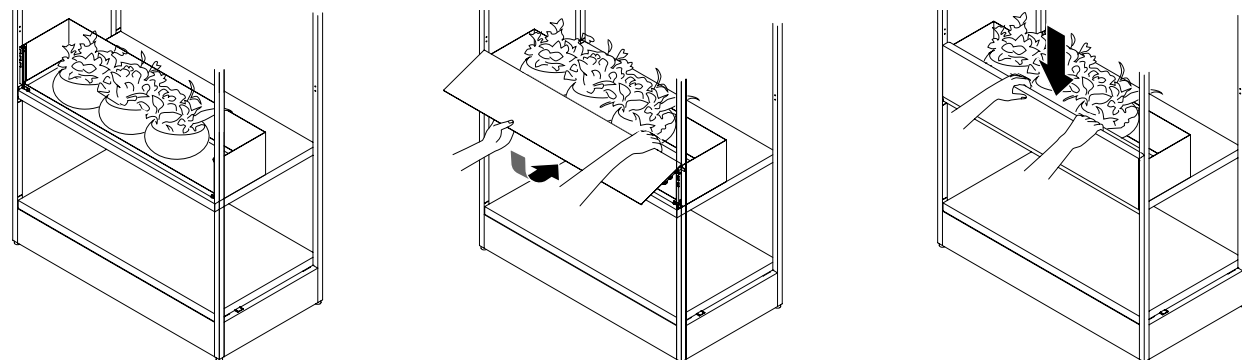

Lastly...

Make sure of the following items when assembling is complete.

- Are bolts completely tightened?
- Are there any scratches, dirt, distortions or malfunctions?
- Are there any packaging materials or trash on the floor?

Lives shelf [Option]

Back panel / End panel / Planter box **Assembly Guide**

This guide will enable you to properly assemble and use <Lives Shelf>. Read this guidebook thoroughly and fully understand its content before assembling the product.

Figure of completed assembly

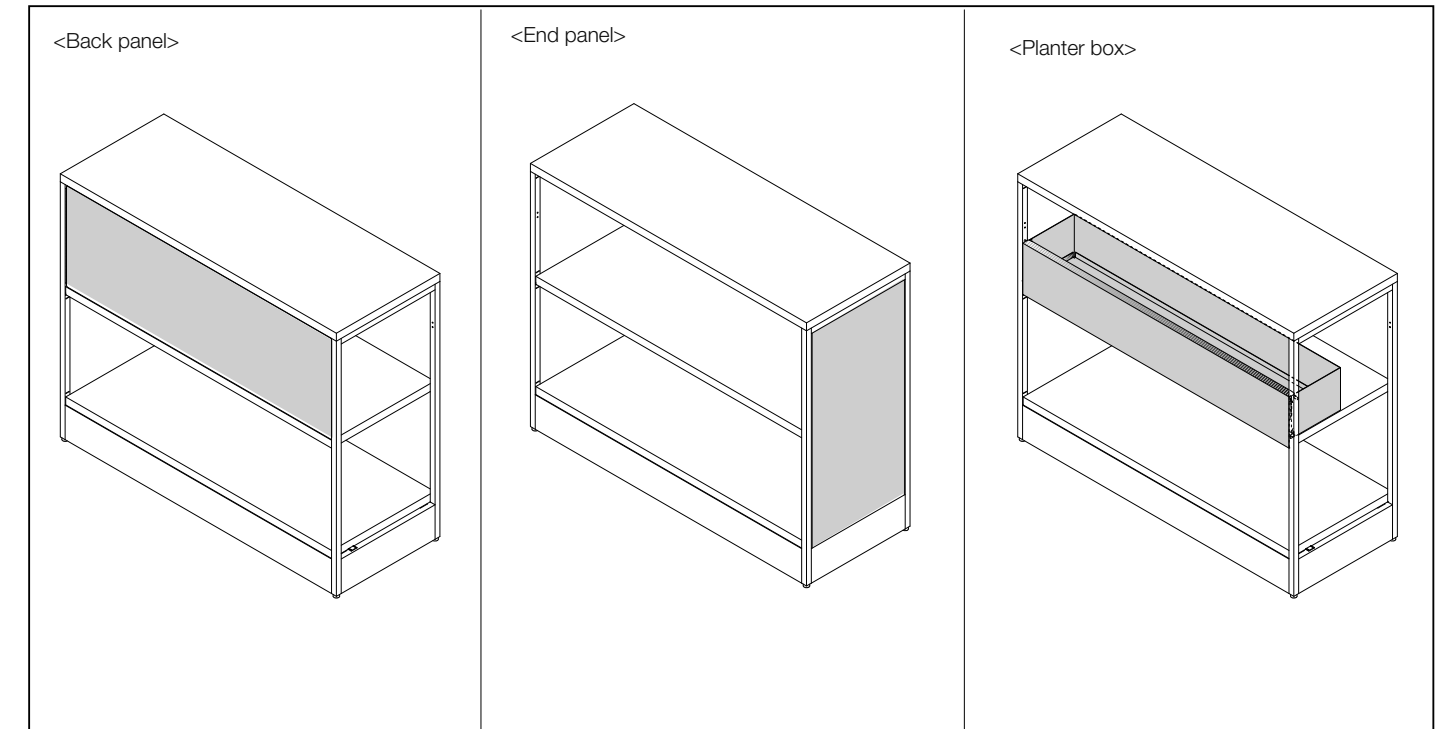

Safety Instructions (Make sure to follow these instructions)

⚠ Caution This indicates that improper handling may cause injury or property damage.

⚠ Caution

- Secure enough workspace before assembly. Failure to do so may cause injury.
- Assembly must be conducted by two or more people. Failure to do so may cause injury.
- Use specified tools for assembly. Improper assembly, such as not completely tightening screws, may cause damage to the product or cause the product to overturn resulting in injury.
- Take gloves off when using power tools. Gloves may get caught in tools causing injury.
- Be careful when handling the ends and backs of parts, and with the gaps between parts. Failure to do so may cause injury.

Assembly Preparations

- Ensure that you have all the parts required.
- Prepare tools for assembly.
- When you inserting screws, lightly tighten before completely tightening them.
- Handle the product with care.

Tools

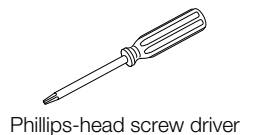
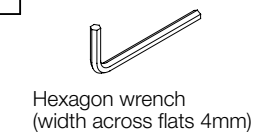

Components Back panel

Make sure that you have all of the necessary parts before assembling.

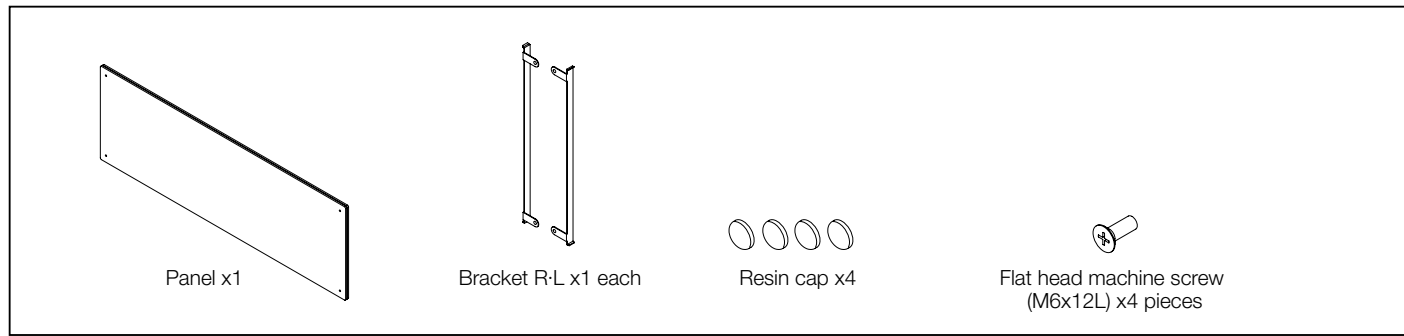

Assembly Instructions Back panel

Follow the instructions to ensure proper assembly.

1 Mounting of back panel

- ① Insert the bracket into the slit of the main unit frame.
- ② Attach the back panel of the main unit to the bracket.
- ③ Attach bracket and panel using flat head machine screws (M6x12L) in 4 places.
- ④ Cover the head of the screw with the resin cap.

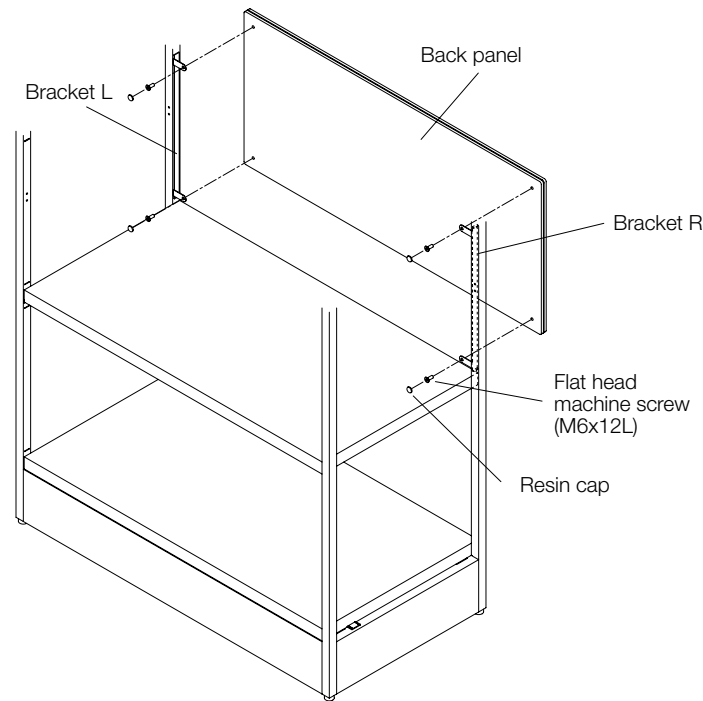

Components End panel

Make sure that you have all of the necessary parts before assembling.

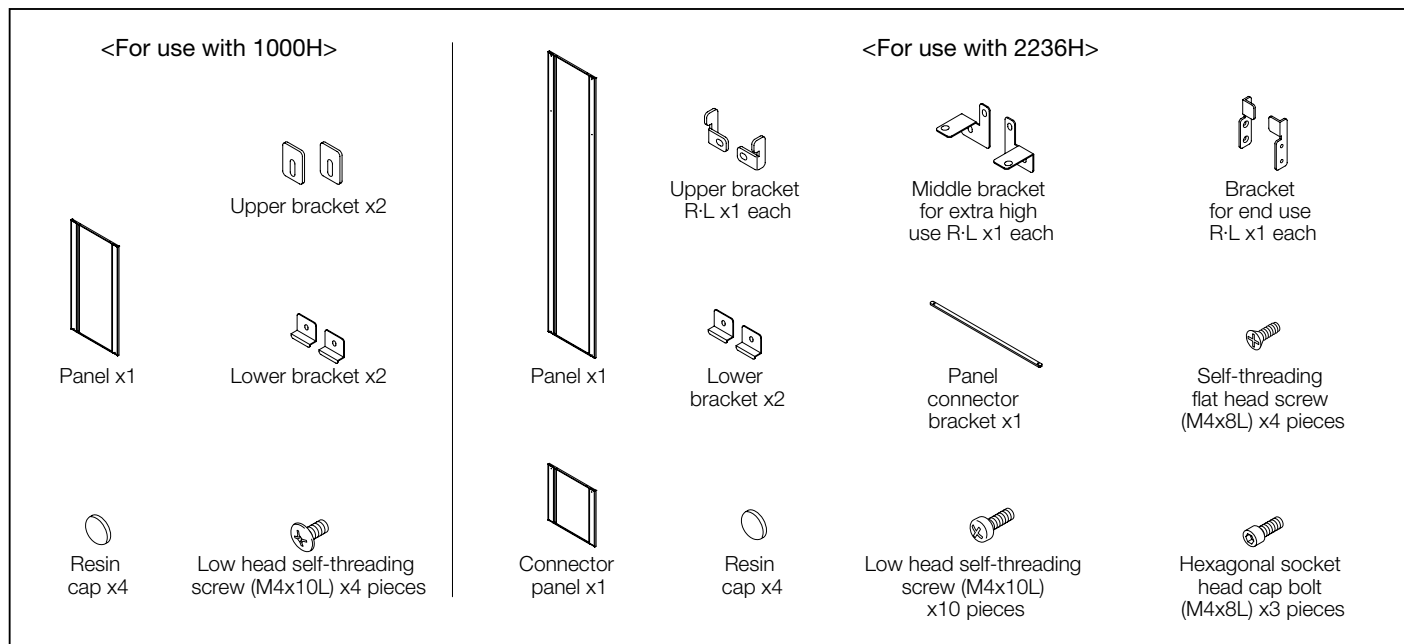

Assembly Instructions End panel

Follow the instructions to ensure proper assembly.

1 Mounting of end panel

- *Attach the connector panel to the panel.**
- ① Insert the panel connection fittings into the groove of the connector panel.
 - ② Insert the Hexagonal socket head cap bolts (M4x8L) from the panel side to the connector panel and fix them in place (3 locations).

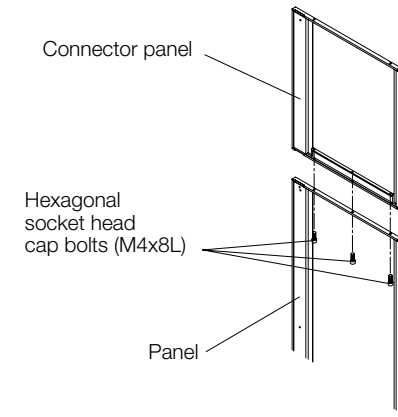

2 Mounting of end panel

- ① Mount bracket for end use to the frame when mounting to end.

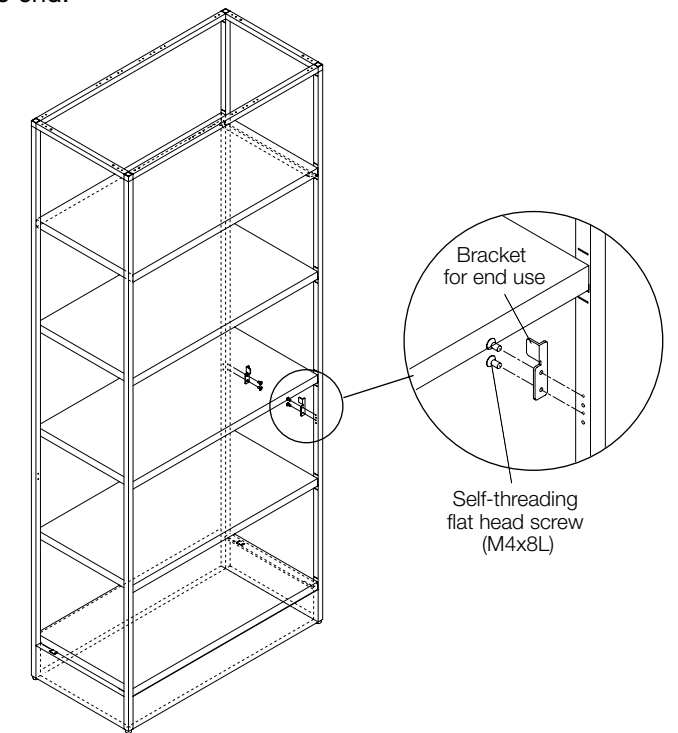

- ② Attach panel to the frame.
- ③ Insert the lower bracket into the slit in the lower part of the side frame and use low head self-threading screws to attach (M4x10L).
- ④ For the middle bracket, temporarily remove screw for shelf at mounting location, jointly fasten, and attach using low head self-threading screws (M4x10L).
- ⑤ Insert upper bracket into slit of upper part of the side frame and use low head self-threading screws (M4x10L) to attach.
- ⑥ Cover the low head self-threading screw (M4x10L) with the resin cap.

